



INDIAN INSTITUTE OF TECHNOLOGY BOMBAY

MATERIALS MANAGEMENT DIVISION

Direct : (+91-22) 2576 8800 (DR) / 8805 (Tender Section)/8801(Local) /
8803,04,06 (Import) / 8802 (Enquiry & Bill tracking)/ 8848(Progress) Email :
drmm@iitb.ac.in, bkganesh@iitb.ac.in

Multi-Station Multi-Axis Hybrid Layer Manufacturing (MSMA-HLM)

Specifications

1. Introduction

Multi-Station Multi-Axis Hybrid Layered Manufacturing (MSMA-HLM) will be used to produce near-net shape of the metallic objects automatically. Its conceptual design will be described here. It will have the following stations along X-axis (see Figure 1):

- Preheating
- Cladding
 - MIG cladding
 - TIG cladding
 - Laser cladding
- Inspection: This will be either a camera or a blue light scanner or a laser scanner.
- Hammering
- Face-milling

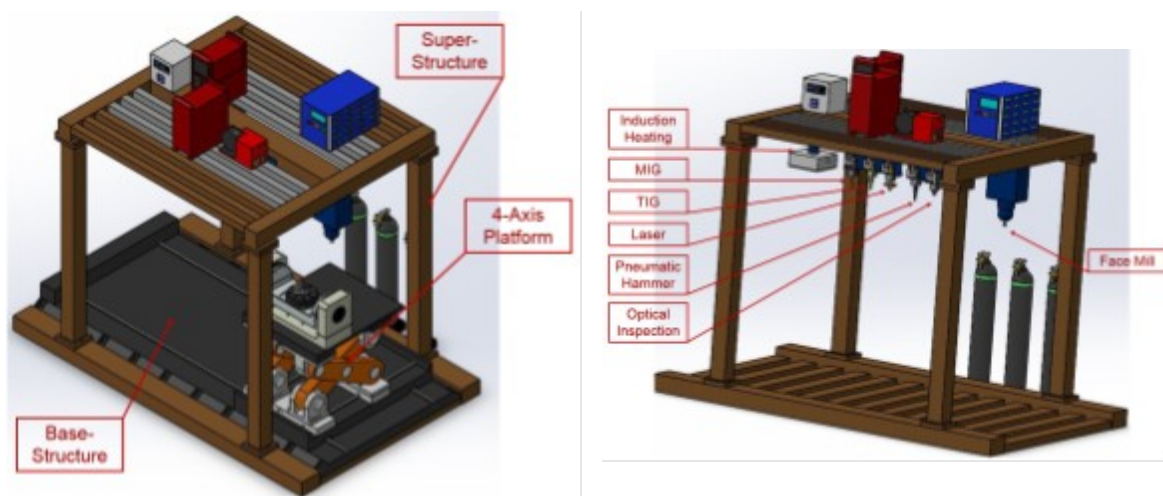

Figure 1: Multi-Station Multi-Axis Hybrid Manufacturing System

The MSMA-HLM system consists of the following four subsystems:



INDIAN INSTITUTE OF TECHNOLOGY BOMBAY

MATERIALS MANAGEMENT DIVISION

Direct : (+91-22) 2576 8800 (DR) / 8805 (Tender Section)/8801(Local) /
8803,04,06 (Import) / 8802 (Enquiry & Bill tracking)/ 8848(Progress) Email :
drmm@iitb.ac.in, bkganesh@iitb.ac.in

- Base structure with X-axis
- 4-axis platform
- Super structure to accommodate the workstations and
- Simultaneous 5-axis CNC controller with PLC and motors.

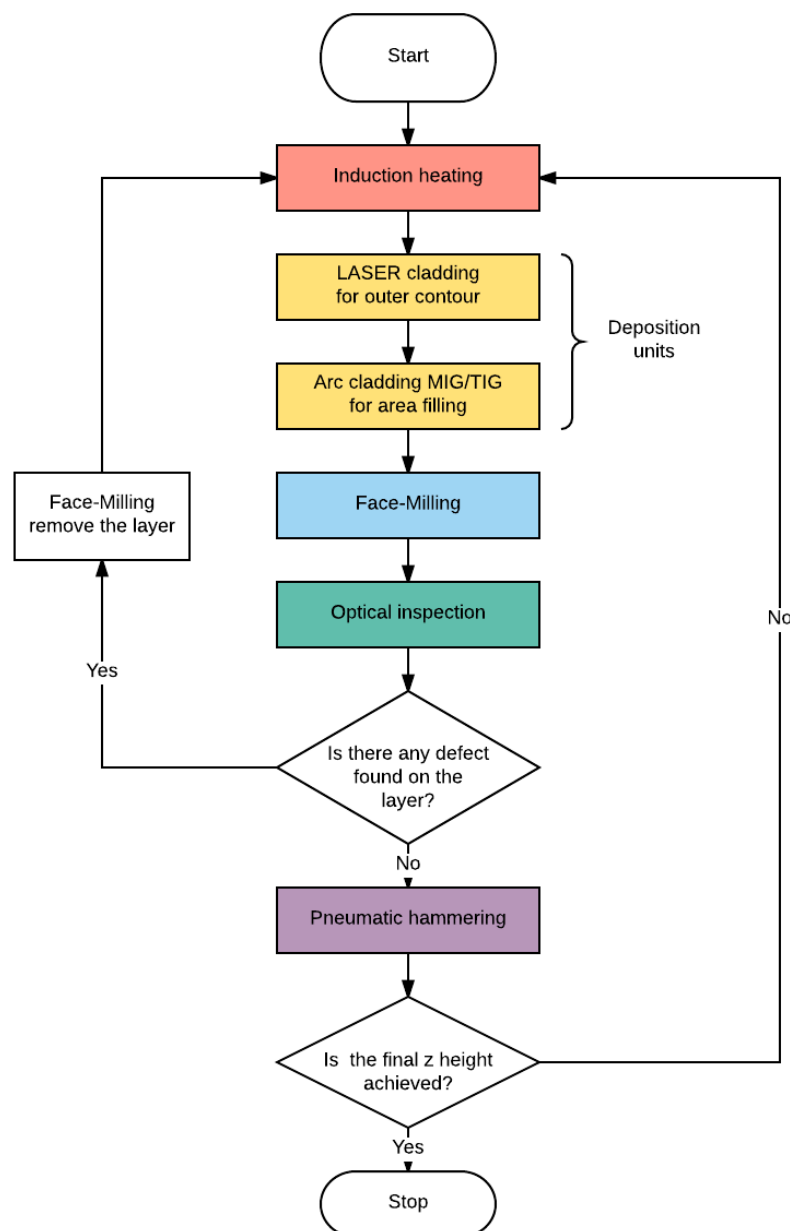

Figure 2: Work flow chart of Multi-Station Multi-axis HLM System

The base-structure is primarily a traditional X-axis on which a 4-axis platform traverses in order to commute among the different stations of the super-structure. The substrate will be



INDIAN INSTITUTE OF TECHNOLOGY BOMBAY MATERIALS MANAGEMENT DIVISION

Direct : (+91-22) 2576 8800 (DR) / 8805 (Tender Section)/8801(Local) /
8803,04,06 (Import) / 8802 (Enquiry & Bill tracking)/ 8848(Progress) Email :
drmm@iitb.ac.in, bkganesh@iitb.ac.in

mounted on the rotary table and the near-net shape will be created in a layer-by-layer manner. A typical sequence of operations to realize any layer is as follows (See, Figure 2):

- The 4-axis platform will move to the induction heating system at the left extreme for preheating the previous layer.
- It will move to the laser cladding system where the boundary loops of a few slices of fine layer thickness (say, 0.5mm) are deposited in 5-axis mode.
- It will move to the arc cladding system to fill the interior in one thick layer in 2.5-axis mode. This will be done by MIG or TIG head depending on the size of the part and precision required.
- It will move to the face milling head at the right extreme for flattening the scalloped surface to the required height.
- It will move to the station for optical inspection where the camera shoots the surface and an image processing software will look for any cracks arising out of a possible process instability such as spatter.
- If the layer will pass the inspection, it will move to the hammering station to relieve the residual stresses. Otherwise, the entire layer will be removed by milling and the layer will be repeated. In future, we shall repair such defects by filling.

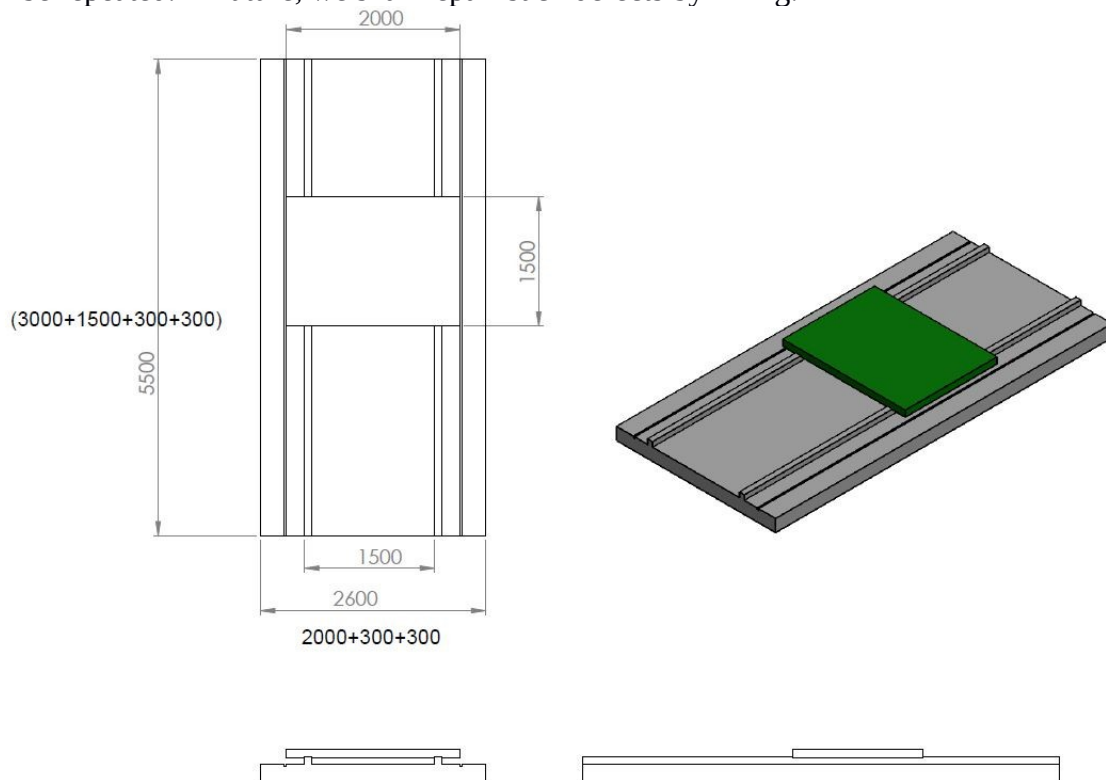

Figure 3: Base Structure with 5-axis motion unit

a. Base Structure with X-axis (see Figure 3)



INDIAN INSTITUTE OF TECHNOLOGY BOMBAY

MATERIALS MANAGEMENT DIVISION

Direct : (+91-22) 2576 8800 (DR) / 8805 (Tender Section)/8801(Local) /
8803,04,06 (Import) / 8802 (Enquiry & Bill tracking)/ 8848(Progress) Email :
drmm@iitb.ac.in, bkganesh@iitb.ac.in

- X-Axis with stroke of at least 3,000mm.
- The rapid traversal speed shall be at least 20,000 mm/min.
- This should be designed to take up a workpiece of 600 kg. The working area of the table is 500mm x 500mm. All the other dimensions in Figure 2 are only suggestive; you may choose them suitably to meet these size and loading conditions.
- Mounting arrangement at regular pitch for various workstations; small items can be mounted on the superstructure and large items such as the laser unit can be at the side.
- Telescopic covers to protect the slides and ball leadscrews
- Lubrication system typically used in the CNC axes. Its capacity should be large enough to cater to the other 4 axes.
- **b. Y and Z-axes**

A platform with 4 axes will shuttle among these stations in order to build the layers. In this 4-axis platform, A and C axes are provided by a conventional trunnion rotary table. There are two options for Y and Z axes as shown in Figure 4, one based on the traditional serial kinematics and the other based on scissor lift parallel kinematics.

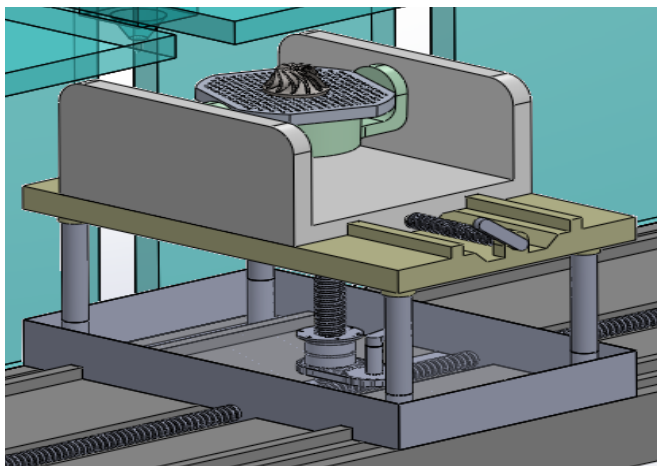

(a) Traditional guideways and ball leadscrew

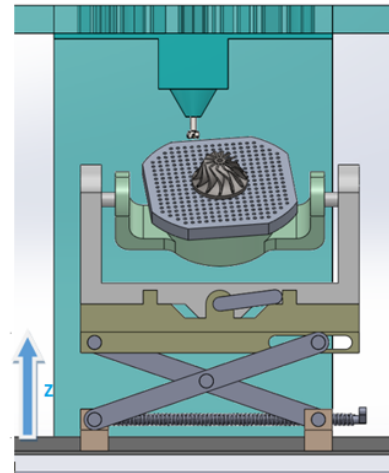

(b) Scissor lift

Figure 4: Two Possible Options for Y and Z Axes

Figure 5 shows the combined arrangement of Y and Z axes of the scissor configuration. The leadscrew along Y is stationary and both the bottom carriages of the scissor lift have a motor each driving the respective nut. When both motors run at the same speed, there will be no Z motion but only Y. When their speeds are unequal, one can achieve the required velocity ratios along Y and Z including only Z motion. The entire motion unit with X, Y, Z, A and C axes is shown in Figure 5.



INDIAN INSTITUTE OF TECHNOLOGY BOMBAY

MATERIALS MANAGEMENT DIVISION

Direct : (+91-22) 2576 8800 (DR) / 8805 (Tender Section)/8801(Local) /
8803,04,06 (Import) / 8802 (Enquiry & Bill tracking)/ 8848(Progress) Email :
drmm@iitb.ac.in, bkganesh@iitb.ac.in

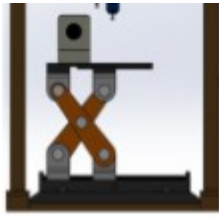

Achieving only Y motion by moving both motors at the same speed

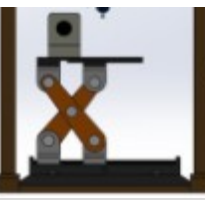
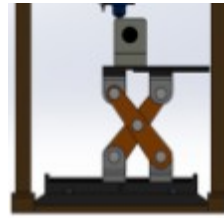

Achieving only Z motion by moving both motors at appropriate speeds

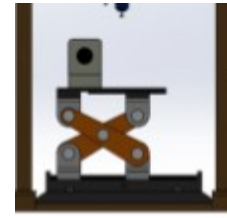

Figure 5: Combined Arrangement of Y and Z Axes

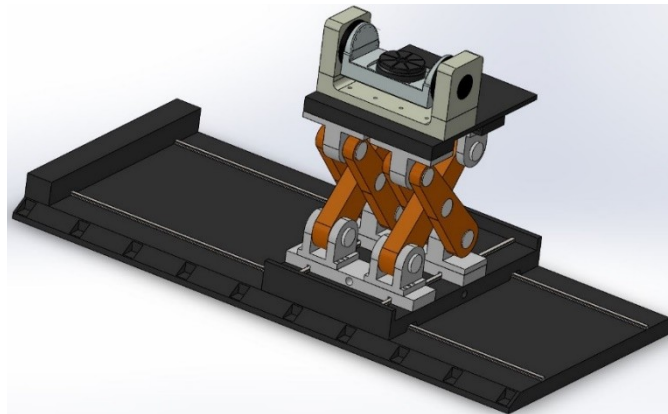

Figure 6: Motion unit

The traditional serial kinematics would require a pit or a raised gantry of about one meter for the guide rods and leadscrews to move down. Therefore, a scissor lift, which is a parallel kinematics, will be preferable to us, as it will provide the following advantages:

- Height of the machine will be less.
- Its rotary joints will be cheaper than the traditional linear axes.
- It is possible to eliminate one of the leadscrews; i.e., two axes can share the same leadscrew.

However, we are open to either of them to suit the comfort of the vendor. The minimum Y stroke is 650 mm and Z stroke is 500 mm. The vendor is welcome to come up with any other configuration too for the Z-axis.

c. Super structure to accommodate the workstations

There are workstations positioned along the X-axis. These are for preheating, cladding, face milling, inspection, and hammering.



INDIAN INSTITUTE OF TECHNOLOGY BOMBAY MATERIALS MANAGEMENT DIVISION

Direct : (+91-22) 2576 8800 (DR) / 8805 (Tender Section)/8801(Local) /
8803,04,06 (Import) / 8802 (Enquiry & Bill tracking)/ 8848(Progress) Email :
drmm@iitb.ac.in, bkganesh@iitb.ac.in

An induction preheating system of about 5kW will be incorporated. Appropriate mounting arrangements are required.

Four slides will be in one station to accommodate a combination of MIG, TIG and Laser cladding systems and a pneumatic hammer. Appropriate mounting arrangements for these stations are required.

Inspection of the face milled layer will be done using a camera. The same station also should be able to accommodate a blue light scanner or a laser scanner for Reverse Engineering. Appropriate mounting arrangements are required for all these equipment.

Face milling and end milling will be done with a spindle with ATC of the following specifications. Appropriate mounting arrangements are required.

Power : A 15/11 kW
Speed : 8000 rpm
Taper : BT40
ATC : 12 Stations

The layout of the workstations (with bounding width) is shown in Figure 7.

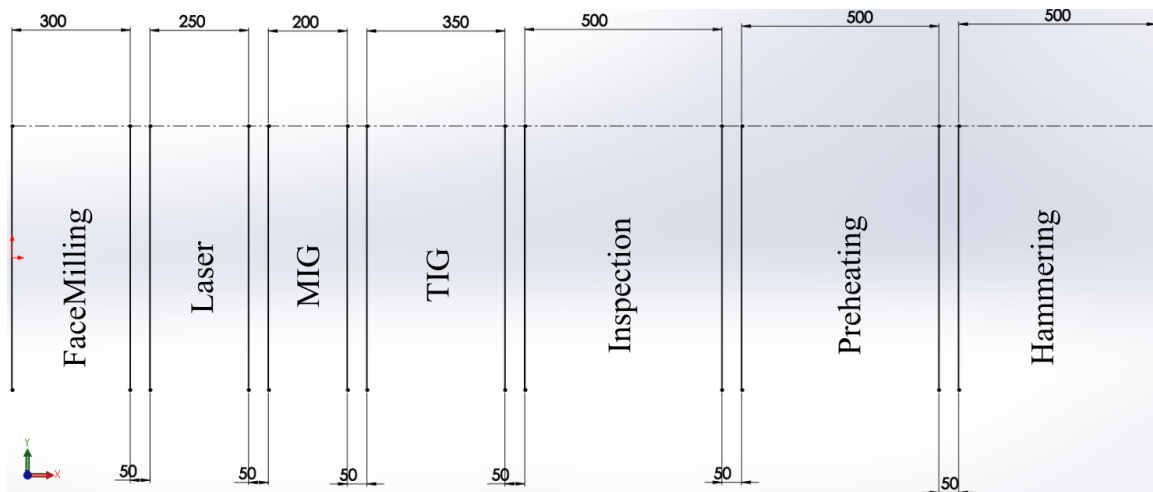

Figure 7: Layout of super structure (all dimensions are in mm)

d. Simultaneous 5-axis CNC controller with PLC and Motors

- Simultaneous 5-axis controller of any brand equivalent, better than Siemens 840 D. Other equivalent makes are also acceptable.
- Additional relay switches for interfacing with the other workstations



INDIAN INSTITUTE OF TECHNOLOGY BOMBAY

MATERIALS MANAGEMENT DIVISION

Direct : (+91-22) 2576 8800 (DR) / 8805 (Tender Section)/8801(Local) /
8803,04,06 (Import) / 8802 (Enquiry & Bill tracking)/ 8848(Progress) Email :
drmm@iitb.ac.in, bkganesh@iitb.ac.in

- o 64 relays (128 M codes)
- o 16 Analog I/O interfacing

2. Conclusions

- The system should be able to sustain in the following critical conditions:
 - o Preheating of the substrate upto 700°C
 - o High temperature involved during cladding MIG cladding
 - o Vibration based mechanical stress relieving: Presently a pneumatic hammer operating at 6 bar, vibrating approximately at 18 Hz is used. In future, we shall use higher frequency as well as wider plate.
 - o Proper ground connection during the MIG, TIG cladding in the 5-axis motion
 - o Shuttling of the motion unit between workstations by a repeatability of 0.01 mm
- *The present order is only for the following:*
 1. Base structure with X-axis
 2. Y and Z-axes of the 4-axis platform
 3. Super structure to accommodate all the workstations
 4. Spindle with ATC
 5. Simultaneous 5-axis CNC controller with PLC and motors.
- The trunnion rotary table will be procured by us separately and supplied to you.
- MIG, TIG and Laser cladding heads and hammer are already available with us. So, you need not supply them.
- Order of stations is flexible.
- What we have shown is a linear arrangement of the stations. You are welcome to propose anything else also which may be even radically different. We shall accept changes as long as our purposes are met.

Item 2: Price includes installation, commissioning, and three years comprehensive warranty.